

TECHNICAL DATA SHEET
NBV series

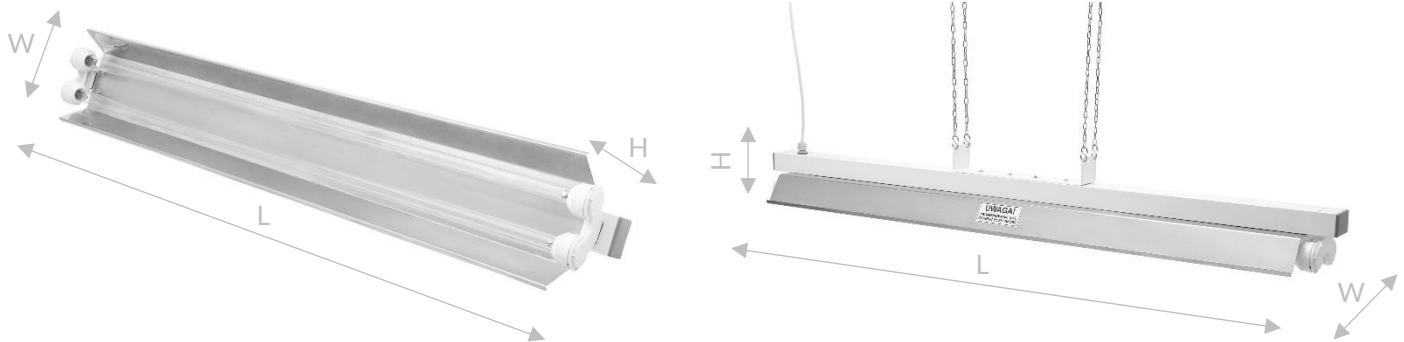

NBV 2x75 IP65
 DIRECT RADIATION UV-C GERMICIDAL LAMP FOR INDUSTRIAL USE

HOW DOES THE DIRECT RADIATION UV-C GERMICIDAL LAMP FOR INDUSTRIAL USE WORK?

Direct radiation germicidal lamps type NBV IP65 are designed to prevent primary and secondary infections in the food, pharmaceutical and cosmetic industries, warehouses, everywhere the production process takes place. Direct radiation germicidal lamps applied in the rooms where airborne pathogenic microorganisms (pathogens) lives, significantly reduces the probability of spread the infection by air. Raising the level of microbiological purity of the air and surface helps to destroy and reduce impact of existing outbreaks of pathogens.

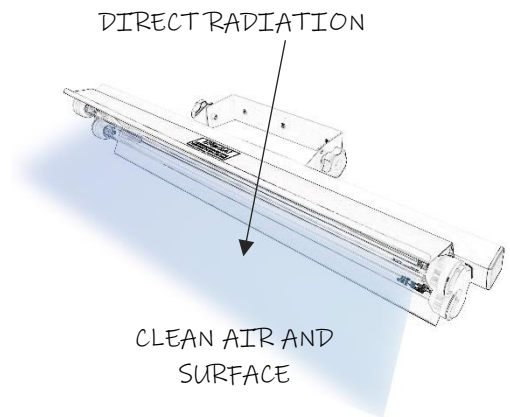

BASIC DATA:

Air flow disinfection function (flow disinfection chamber)	no
Direct radiation function	yes
Presence of people, animals, plants inside the room during disinfection process	not allowed
Mounting type	wall-mounted/ ceiling mounted (both types of hangers in standard)
Working time counter	no
External bulbs	yes, 2 bulbs (covered with anti-splashing foil)
Casing material	powder laquered aluminium
Reflector material	high quality reflective aluminium
Switch on/off	no
Ambient temperature	+10°C to +40°C
Relative humidity	30% to 70%
Atmospheric pressure	700 hPa to 1060 hPa
Declaration of conformity	yes
User's manual English version	yes

TECHNICAL DATA SHEET

NBV series

NBV 2x75 IP65

DIRECT RADIATION UV-C GERMICIDAL LAMP FOR INDUSTRIAL USE

TECHNICAL DATA:

Supply voltage	230 V, 50 Hz
Power consumption	160 W
UV-C bulbs (Philips/Osram)	2 x 75 W (TUV/HNS)
UV-C radiation wave-length	253,7 nm
Useful lifetime of the UV-C bulbs	min. 8000 h
Radiation intensity of the external UV-C tube at the distance of 1m	6,8 W/m ²
Effective area of the lamp	30-40 m ²
Exposure angle adjustment range (wall mounted type)	150°
Anti-shock protection class	I
Ingress Protection Code	IP 65
Lamp body dimensions (L x W x H)	1280 x 220 x 170 mm
Overall dimensions (wall mounted type L x W x H)	1280 x 220 x 200 mm
Lamp body mass	5,6 kg
Wall holder length/ ceiling chains length	49 cm / 100 cm
Power cord length	0,8 m

APPLICATION RECOMMENDATIONS:

- Pharmaceutical industry
- Food industry
- Cosmetic industry
- Warehouses
- Industrial kitchens



Anti-splashing foil protection



Ultra-Viol's realisation